

TOSHIBA PHOTOCOUPLER GaAs IRED & PHOTO-IC

TLP250

TRANSISTOR INVERTER
 INVERTER FOR AIR CONDITIONOR
 IGBT GATE DRIVE
 POWER MOS FET GATE DRIVE

The TOSHIBA TLP250 consists of a GaAs light emitting diode and a integrated photodetector.
 This unit is 8-lead DIP package.
 TLP250 is suitable for gate driving circuit of IGBT or power MOS FET.

- Input Threshold Current : $I_F = 5\text{mA (Max.)}$
- Supply Current (I_{CC}) : 11mA (Max.)
- Supply Voltage (V_{CC}) : $10\text{-}35\text{V}$
- Output Current (I_O) : $\pm 1.5\text{A (Max.)}$
- Switching Time (t_{pLH}/t_{pHL}) : $1.5\mu\text{s (Max.)}$
- Isolation Voltage : $2500\text{V}_{\text{rms (Min.)}}$
- UL Recognized : $\text{UL1577, File No.E67349}$
- Option (D4) type
 VDE Approved : $\text{DIN VDE0884/06.92, Certificate No.76823}$
 Maximum Operating Insulation Voltage : 630V_{PK}
 Highest Permissible Over Voltage : 4000V_{PK}

(Note) When a VDE0884 approved type is needed, please designate the "Option (D4)"

- Creepage Distance : 6.4mm (Min.)
- Clearance : 6.4mm (Min.)

SCHEMATIC

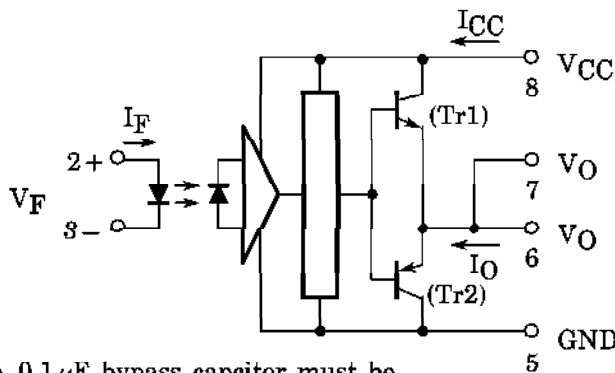

A $0.1\mu\text{F}$ bypass capacitor must be connected between pin 8 and 5 (See Note 5).

TRUTH TABLE

		Tr1	Tr2
Input LED	ON	ON	OFF
	OFF	OFF	ON

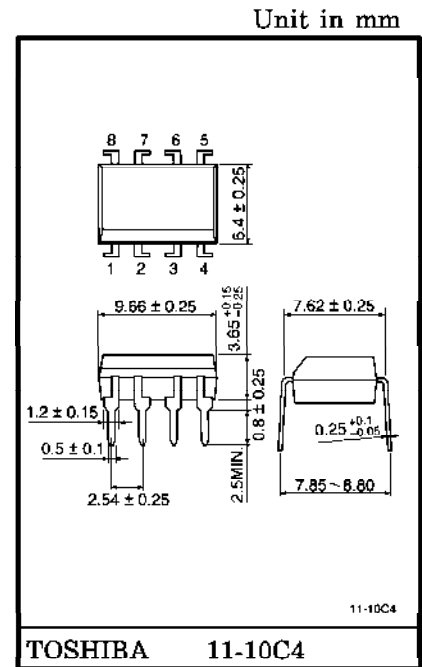

Weight : 0.54g

PIN CONFIGURATION (TOP VIEW)

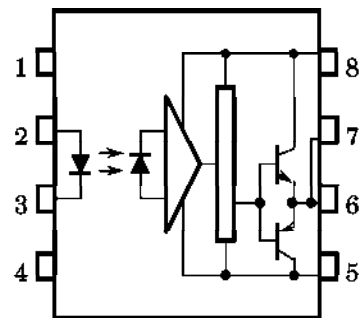

- 1 : N.C.
- 2 : ANODE
- 3 : CATHODE
- 4 : N.C.
- 5 : GND
- 6 : VO (OUTPUT)
- 7 : VO
- 8 : VCC

961001EBC2

● TOSHIBA is continually working to improve the quality and the reliability of its products. Nevertheless, semiconductor devices in general can malfunction or fail due to their inherent electrical sensitivity and vulnerability to physical stress. It is the responsibility of the buyer, when utilizing TOSHIBA products, to observe standards of safety, and to avoid situations in which a malfunction or failure of a TOSHIBA product could cause loss of human life, bodily injury or damage to property. In developing your designs, please ensure that TOSHIBA products are used within specified operating ranges as set forth in the most recent products specifications. Also, please keep in mind the precautions and conditions set forth in the TOSHIBA Semiconductor Reliability Handbook.

ABSOLUTE MAXIMUM RATINGS (Ta = 25°C)

CHARACTERISTIC		SYMBOL	RATING	UNIT	
LED	Forward Current	I _F	20	mA	
	Forward Current Derating (Ta ≥ 70°C)	ΔI _F /ΔTa	-0.36	mA/°C	
	Peak Transient Forward Current (Note 1)	I _{FPT}	1	A	
	Reverse Voltage	V _R	5	V	
	Junction Temperature	T _j	125	°C	
DETECTOR	"H" Peak Output Current (P _W ≤ 2.5 μs, f ≤ 15kHz) (Note 2)		I _{OPH}	-1.5	A
	"L" Peak Output Current (P _W ≤ 2.5 μs, f ≤ 15kHz) (Note 2)		I _{OPL}	+1.5	A
	Output Voltage	(Ta ≤ 70°C)	V _O	35	V
		(Ta = 85°C)		24	
	Supply Voltage	(Ta ≤ 70°C)	V _{CC}	35	V
		(Ta = 85°C)		24	
	Output Voltage Derating (Ta ≥ 70°C)		ΔV _O /ΔTa	-0.73	V/°C
	Supply Voltage Derating (Ta ≥ 70°C)		ΔV _{CC} /ΔTa	-0.73	V/°C
	Junction Temperature		T _j	125	°C
Operating Frequency (Note 3)		f	25	kHz	
Operating Temperature Range		T _{opr}	-20~85	°C	
Storage Temperature Range		T _{stg}	-55~125	°C	
Lead Soldering Temperature (10s)		T _{sol}	260	°C	
Isolation Voltage (AC, 1min., R.H. ≤ 60%) (Note 4)		BV _S	2500	V _{rms}	

(Note 1) Pulse width P_W ≤ 1 μs, 300pps

(Note 2) Exponential Waveform

(Note 3) Exponential Waveform, I_{OPH} ≤ -1.0A (≤ 2.5 μs), I_{OPL} ≤ +1.0A (≤ 2.5 μs)

(Note 4) Device considered a two terminal device : pins 1,2,3 and 4 shorted together, and pins 5, 6, 7 and 8 shorted together.

(Note 5) A ceramic capacitor (0.1 μF) should be connected from pin 8 to pin 5 to stabilize the operation of the high gain linear amplifier. Failure to provide the bypassing may impair the switching property. The total lead length between capacitor and coupler should not exceed 1cm.

RECOMMENDED OPERATING CONDITIONS

CHARACTERISTIC	SYMBOL	MIN.	TYP.	MAX.	UNIT
Input Current, ON	I _F (ON)	7	8	10	mA
Input Voltage, OFF	V _F (OFF)	0	—	0.8	V
Supply Voltage	V _{CC}	15	—	30 20	V
Peak Output Current	I _{OPH} / I _{OPL}	—	—	±0.5	A
Operating Temperature	T _{opr}	-20	25	70 85	°C

961001EBC2'

- Gallium arsenide (GaAs) is a substance used in the products described in this document. GaAs dust and fumes are toxic. Do not break, cut or pulverize the product, or use chemicals to dissolve them. When disposing of the products, follow the appropriate regulations. Do not dispose of the products with other industrial waste or with domestic garbage.
- The products described in this document are subject to foreign exchange and foreign trade control laws.
- The information contained herein is presented only as a guide for the applications of our products. No responsibility is assumed by TOSHIBA CORPORATION for any infringements of intellectual property or other rights of the third parties which may result from its use. No license is granted by implication or otherwise under any intellectual property or other rights of TOSHIBA CORPORATION or others.
- The information contained herein is subject to change without notice.

ELECTRICAL CHARACTERISTICS (Ta = -20~70°C, Unless otherwise specified)

CHARACTERISTIC	SYMBOL	TEST CIR-CUIT	TEST CONDITION	MIN.	TYP.*	MAX.	UNIT	
Input Forward Voltage	V _F	—	I _F = 10mA, Ta = 25°C		1.6	1.8	V	
Temperature Coefficient of Forward Voltage	ΔV _F /ΔTa	—	I _F = 10mA	—	-2.0	—	mV/°C	
Input Reverse Current	I _R	—	V _R = 5V, Ta = 25°C		—	10	μA	
Input Capacitance	C _T	—	V = 0, f = 1MHz, Ta = 25°C	—	45	250	pF	
Output Current	“H” Level	I _{OPH}	3	V _{CC} = 30V (*1)	I _F = 10mA V ₈₋₆ = 4V	-0.5	-1.5	A
	“L” Level	I _{OPL}	2			I _F = 0 V ₆₋₅ = 2.5V	0.5	
Output Voltage	“H” Level	V _{OH}	4	V _{CC1} = +15V, V _{EE1} = -15V R _L = 200Ω, I _F = 5mA	11	12.8	—	V
	“L” Level	V _{OL}	5	V _{CC1} = +15V, V _{EE1} = -15V R _L = 200Ω, V _F = 0.8V	—	-14.2	-12.5	
Supply Current	“H” Level	I _{CCH}	—	V _{CC} = 30V, I _F = 10mA Ta = 25°C	—	7	—	mA
				V _{CC} = 30V, I _F = 10mA	—	—	11	
	“L” Level	I _{CCL}	—	V _{CC} = 30V, I _F = 0mA Ta = 25°C	—	7.5	—	
				V _{CC} = 30V, I _F = 0mA	—	—	11	
Threshold Input Current	“Output L→H”	I _{FLH}	—	V _{CC1} = +15V, V _{EE1} = -15V R _L = 200Ω, V _O > 0V	—	1.2	5	mA
Threshold Input Voltage	“Output H→L”	V _{FHL}	—	V _{CC1} = +15V, V _{EE1} = -15V R _L = 200Ω, V _O < 0V	0.8	—	—	V
Supply Voltage	V _{CC}	—		10	—	35	V	
Capacitance (Input-Output)	C _S	—	V _S = 0, f = 1MHz Ta = 25°C	—	1.0	2.0	pF	
Resistance (Input-Output)	R _S	—	V _S = 500V, Ta = 25°C R.H. ≤ 60%	1 × 10 ¹²	10 ¹⁴	—	Ω	

* All typical values are at Ta = 25°C (*1) : Duration of I_O time ≤ 50μs

SWITCHING CHARACTERISTICS (Ta = -20~70°C, Unless otherwise specified)

CHARACTERISTIC		SYMBOL	TEST CIR-CUTT	TEST CONDITION	MIN.	TYP.*	MAX.	UNIT
Propagation Delay Time	L→H	t _{pLH}	6	I _F = 8mA V _{CC1} = +15V, V _{EE1} = -15V R _L = 200Ω	—	0.15	0.5	μs
	H→L	t _{pHL}			—	0.15	0.5	
Output Rise Time		t _r			—	—	—	
Output Fall Time		t _f			—	—	—	
Common Mode Transient Immunity at High Level Output		C _{MH}	7	V _{CM} = 600V, I _F = 8mA V _{CC} = 30V, Ta = 25°C	-5000	—	—	V / μs
Common Mode Transient Immunity at Low Level Output		C _M L	7	V _{CM} = 600V, I _F = 0mA V _{CC} = 30V, Ta = 25°C	5000	—	—	V / μs

* All typical values are at Ta = 25°C

TEST CIRCUIT 1 :

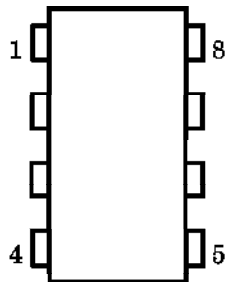

TEST CIRCUIT 2 : IOPL

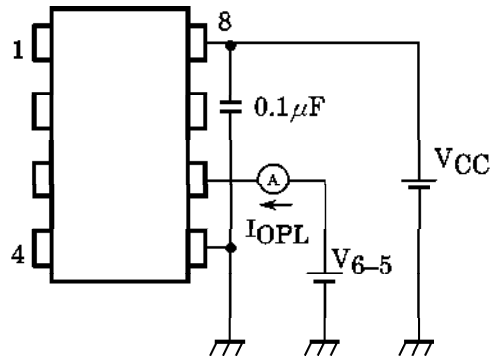

TEST CIRCUIT 3 : IOPH

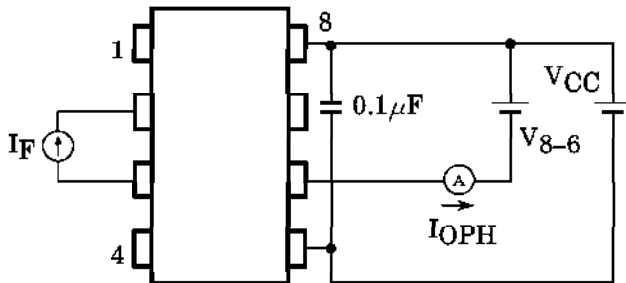

TEST CIRCUIT 4 : VOH

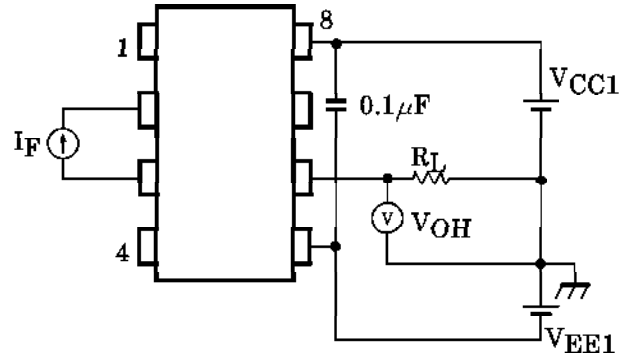

TEST CIRCUIT 5 : VOL

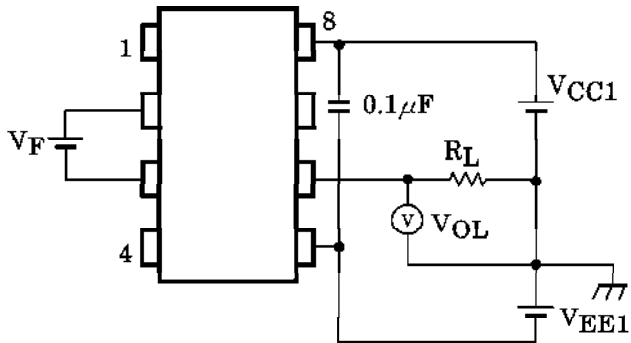

TEST CIRCUIT 6 : t_{pLH} , t_{pHL} , t_r , t_f

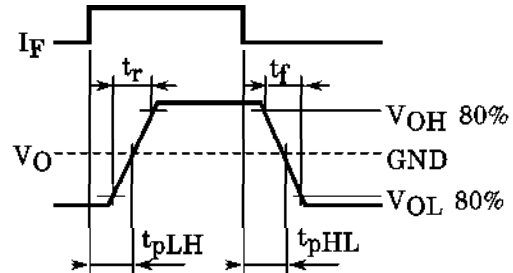
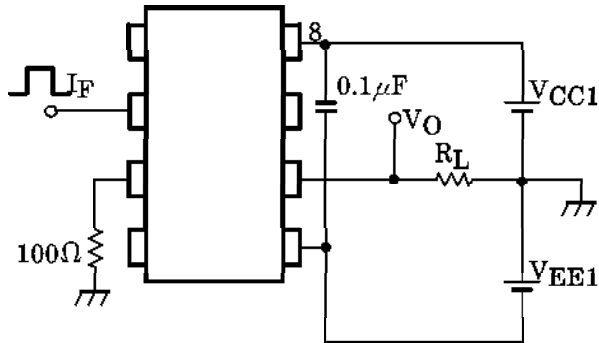

TEST CIRCUIT 7 : C_{MH} , C_{ML}

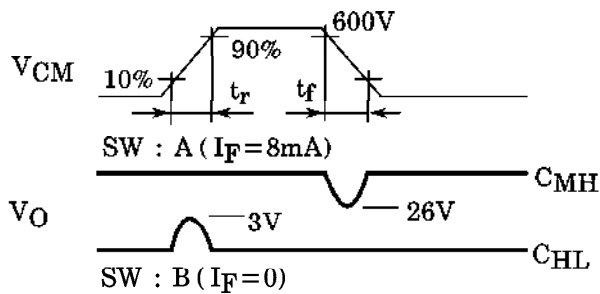
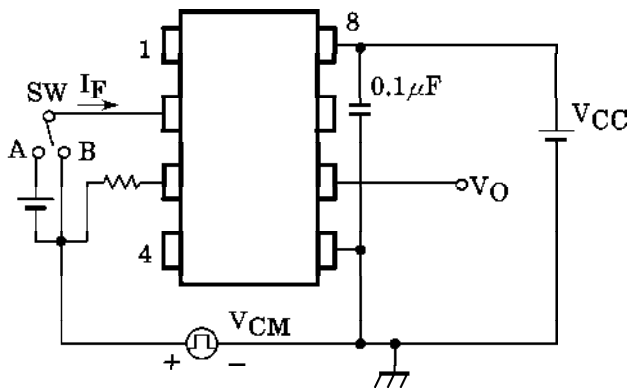

$$C_{ML} = \frac{480(V)}{t_r(\mu s)}$$

$$C_{MH} = \frac{480(V)}{t_f(\mu s)}$$

C_{ML} (C_{MH}) is the maximum rate of rise (fall) of the common mode voltage that can be sustained with the output voltage in the low (high) state.

