

# MBR20200CT

## Dual High Voltage Schottky Rectifier

### Features:

- Low Forward Voltage Drop
- Low Power Loss and High Efficiency
- High Surge Capability
- Rohs Compliant
- Matte Tin(Sn) Lead Finish
- Terminal Leads Surface is Corrosion Resistant and can withstand to 260°C
- Wave Soldering or per MIL-STD-750 Method 2026.

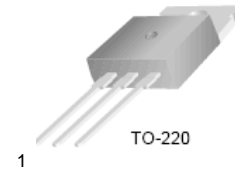

Mark : MBR20200CT

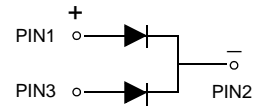

### Absolute Maximum Ratings\* $T_a = 25^\circ\text{C}$ unless otherwise noted

Symbol	Parameter	Value	Unit
$V_{RRM}$	Maximum Repetitive Reverse Voltage	200	V
$V_R$	Maximum DC Reverse Voltage	200	V
$I_{F(AV)}$	Average Rectified Forward Current, $T_c=115^\circ\text{C}$	10 (Per Leg) 20(Per Device)	A
$I_{FSM}$	Peak Forward Surge Current, 8.3mS Half Sine wave	150	A
$T_{STG}$	Storage Temperature Range	-55 ~ 150	$^\circ\text{C}$
$T_J$	Operating Junction Temperature	150	$^\circ\text{C}$

\* These ratings are limiting values above which the serviceability of any semiconductor device may be impaired.

### Thermal Characteristics\* $T_a=25^\circ\text{C}$ unless otherwise noted

Symbol	Parameter	Max	Unit
$R_{\theta JC}$	Thermal Resistance, Junction to Case per Leg	1.5	$^\circ\text{C/W}$
$R_{\theta JA}$	Thermal Resistance, Junction to Ambient per Leg	62.5	$^\circ\text{C/W}$

\* MIL standard 883-1012 & JESD51-10

### Electrical Characteristics\* $T_a=25^\circ\text{C}$ unless otherwise noted

Symbol	Parameter	Test Condition	Min.	Max.	Unit
$I_R$	Reverse Current	$V_R=200\text{V}$ $T_C = 25^\circ\text{C}$ $V_R=200\text{V}$ $T_C = 125^\circ\text{C}$		0.2 5	mA
$V_F$	Forward Voltage	$I_F=10\text{A}$ $T_C = 25^\circ\text{C}$ $I_F=10\text{A}$ $T_C = 125^\circ\text{C}$ $I_F=20\text{A}$ $T_C = 25^\circ\text{C}$ $I_F=20\text{A}$ $T_C = 125^\circ\text{C}$		0.9 0.8 1.0 0.9	V

\* DC Item are tested by Pulse Test : Pulse Width $\leq$ 300us, Duty Cycle $\leq$ 2%

# Typical Performance Characteristics

Figure 1. Forward Current Characteristics

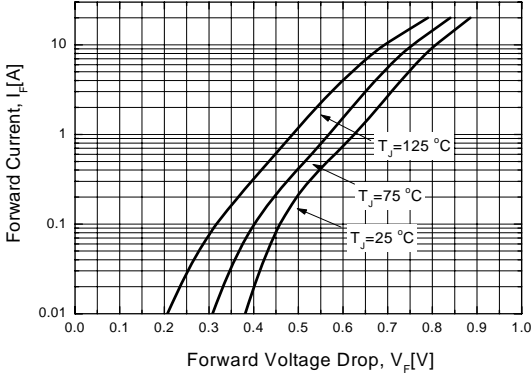

Figure 2. Reverse Leakage Current

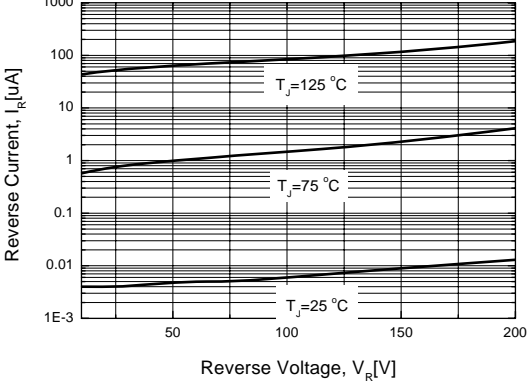

Figure 3. Junction Capacitance

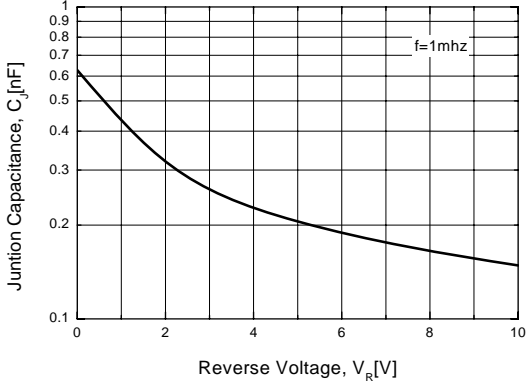
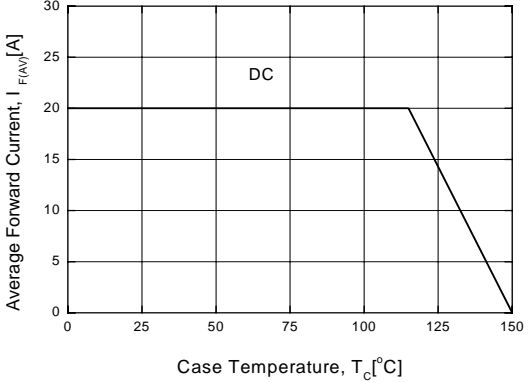

Figure 4. Power Derating



# Package Dimensions

## TO-220(DUAL GAUGE)

Dimensions are In mm

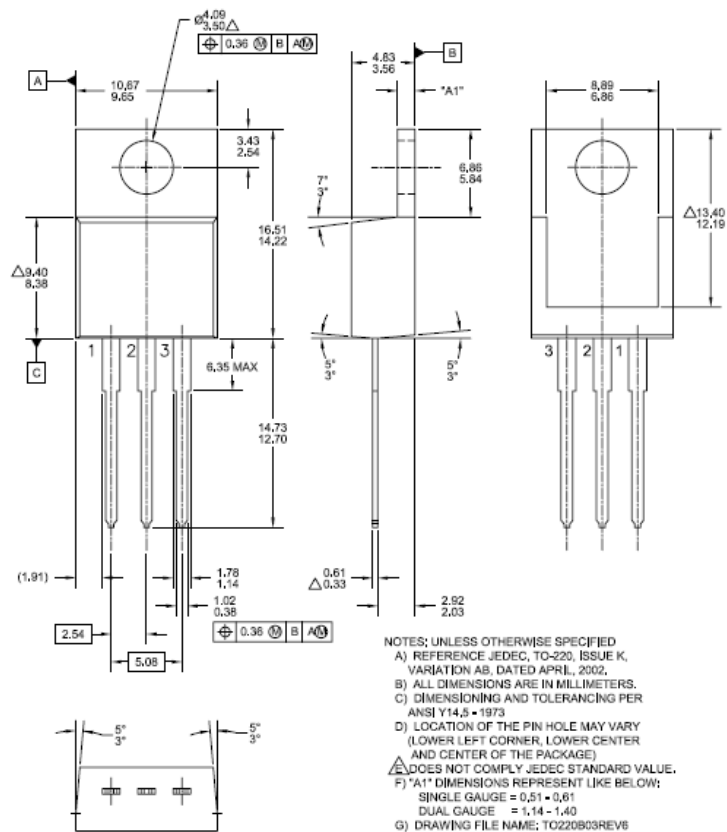

Dimensions in Millimeters