

# PC713V/PC714V

## High Isolation Voltage Type, General Purpose Photocoupler

- \* Lead forming type (I type) and taping reel type (P type) are also available. (PC713V/PC714V/PC713VP/PC714VP) (Page 656)
- \*\* TÜV (VDE0884) approved type is also available as an option.

### ■ Features

1. TTL compatible output
2. Current transfer ratio  
(CTR : MIN. 50% at  $I_F=5\text{mA}$ ,  $V_{CE}=5\text{V}$ )
3. Low collector dark current  
( $I_{CBO}$  : MAX.  $10^{-7}\text{A}$  at  $V_{CE}=20\text{V}$ )
4. High isolation voltage between input and output ( $V_{iso}$  : 5 000V<sub>rms</sub>)
5. Recognized by UL, file No. E64380

### ■ Applications

1. System appliances, measuring instruments
2. Registers, copiers, automatic vending machines
3. Electric home appliances such as fan heaters
4. Medical instruments, physical and chemical equipment
5. Signal transmission between circuits of different potentials and impedances

### ■ Absolute Maximum Ratings (Ta=25°C)

	Parameter	Symbol	Rating	Unit
Input	Forward current	$I_F$	50	mA
	Peak forward current	$I_{FM}$	1	A
	Reverse voltage	$V_R$	6	V
	Power dissipation	P	70	mW
Output	Collector-emitter voltage	$V_{CEO}$	35	V
	Emitter-collector voltage	$V_{ECO}$	6	V
	Collector-base voltage	$V_{CBO}$	35	V
	Emitter-base voltage	$V_{EBO}$	6	V
	Collector current	$I_C$	50	mA
	Collector power dissipation	$P_C$	150	mW
	Total power dissipation	$P_{tot}$	170	mW
	Isolation voltage	$V_{iso}$	5 000	V <sub>rms</sub>
Operating temperature		$T_{op}$	-25 to +100	°C
Storage temperature		$T_{sg}$	-40 to +125	°C
Soldering temperature		$T_{sol}$	260	°C

\*1 Pulse width  $\leq 100\ \mu\text{s}$ , Duty ratio = 0.001

\*2 Applies only to PC713V

\*3 40 to 60%RH, AC for 1 minute

\*4 For 10 seconds

### ■ Outline Dimensions

(Unit : mm)

#### PC713V

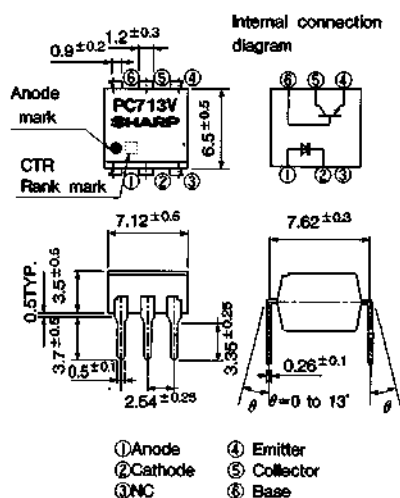

#### PC714V

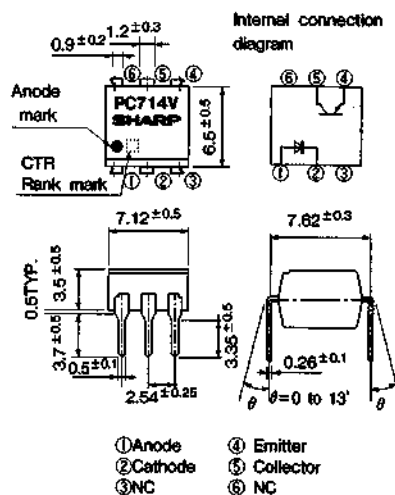

### Electro-optical Characteristics

(T<sub>a</sub> = 25°C)

Parameter		Symbol	Conditions	MIN.	TYP.	MAX.	Unit
Input	Forward voltage	V <sub>F</sub>	I <sub>F</sub> = 20mA	—	1.2	1.4	V
	Peak forward voltage	V <sub>FM</sub>	I <sub>FM</sub> = 0.5A	—	—	3.0	V
	Reverse current	I <sub>R</sub>	V <sub>R</sub> = 4V	—	—	10	μA
	Terminal capacitance	C <sub>t</sub>	V = 0, f = 1kHz	—	30	250	pF
Output	Collector dark current	I <sub>CEO</sub>	V <sub>CE</sub> = 20V, I <sub>F</sub> = 0, *R <sub>BE</sub> = ∞	—	—	10 <sup>-7</sup>	A
Transfer characteristics	*Current transfer ratio	CTR	I <sub>F</sub> = 5mA, V <sub>CE</sub> = 5V, *R <sub>BE</sub> = ∞	50	—	600	%
	Collector-emitter saturation voltage	V <sub>CE(sat)</sub>	I <sub>F</sub> = 20mA, I <sub>C</sub> = 1mA, *R <sub>BE</sub> = ∞	—	0.1	0.2	V
	Isolation resistance	R <sub>ISO</sub>	DC500V, 40 to 60%RH	5 × 10 <sup>10</sup>	10 <sup>11</sup>	—	Ω
	Floating capacitance	C <sub>f</sub>	V = 0, f = 1MHz	—	0.6	1.0	pF
	Cut-off frequency	f <sub>c</sub>	V <sub>CE</sub> = 5V, I <sub>C</sub> = 2mA, R <sub>L</sub> = 100Ω, *R <sub>BE</sub> = ∞	—	80	—	kHz
	Response time	Rise time	t <sub>r</sub>	V <sub>CE</sub> = 2V, I <sub>C</sub> = 2mA	—	4	18
Fall time		t <sub>f</sub>	R <sub>L</sub> = 100Ω, *R <sub>BE</sub> = ∞	—	3	18	μs

\*5 Applies only to PC713V

\*6 Classification table of current transfer ratio is shown below.

Model No	Rank mark	CTR(%)
PC713V1/PC714V1	A	80 to 160
PC713V2/PC714V2	B	130 to 260
PC713V3/PC714V3	C	200 to 400
PC713V5/PC714V5	A or B	80 to 260
PC713V6/PC714V6	B or C	130 to 400
PC713V8/PC714V8	A, B or C	80 to 400
PC713V/PC714V	A, B, C or no marking	50 to 600

## Measurement conditions

I<sub>F</sub> = 5mAV<sub>CE</sub> = 5VT<sub>a</sub> = 25°C

**Fig. 1 Forward Current vs. Ambient Temperature**

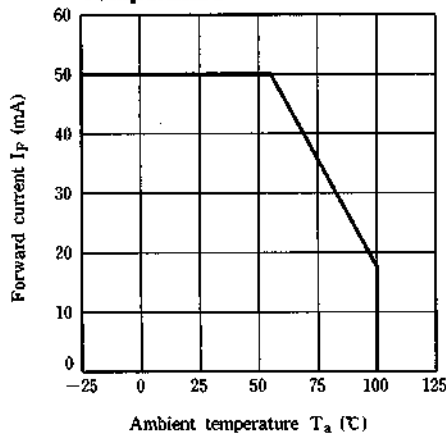

**Fig. 2 Collector Power Dissipation vs. Ambient Temperature**

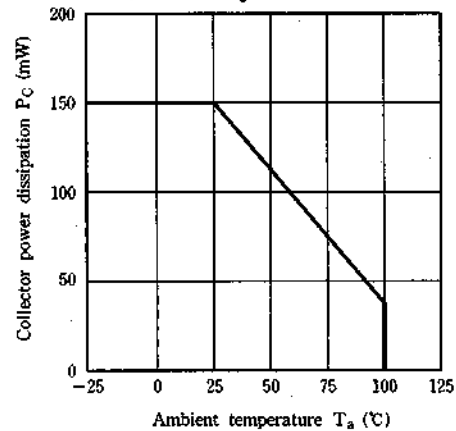

**Fig. 3 Peak Forward Current vs. Duty Ratio**

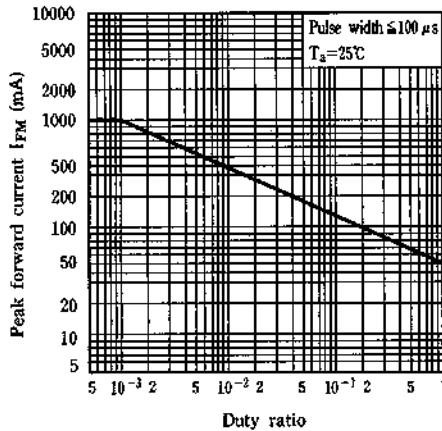

**Fig. 4 Forward Current vs. Forward Voltage**

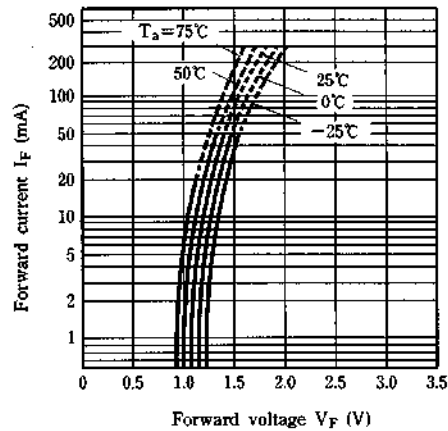

**Fig. 5 Current Transfer Ratio vs. Forward Current**

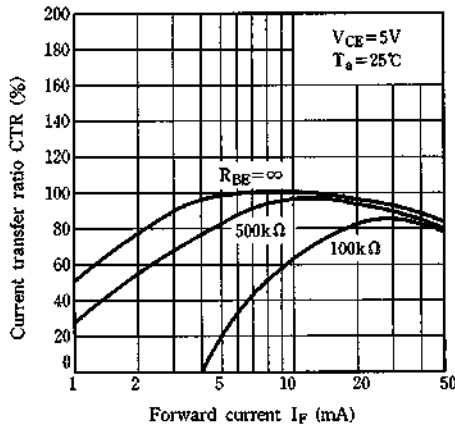

**Fig. 6 Collector Current vs. Collector-emitter Voltage**

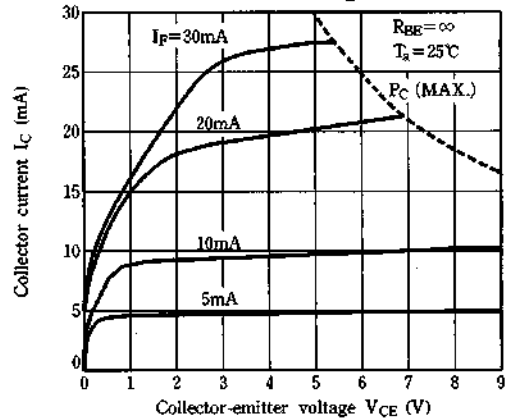

**Fig. 7 Relative Current Transfer Ratio vs. Ambient Temperature**

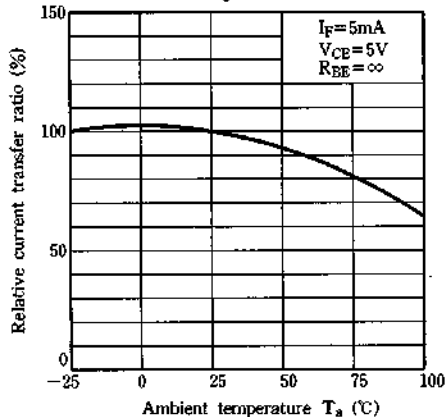

**Fig. 8 Collector-emitter Saturation Voltage vs. Ambient Temperature**

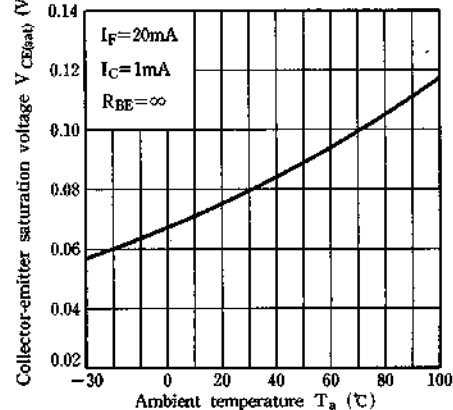

**Fig. 9 Collector Dark Current vs. Ambient Temperature**

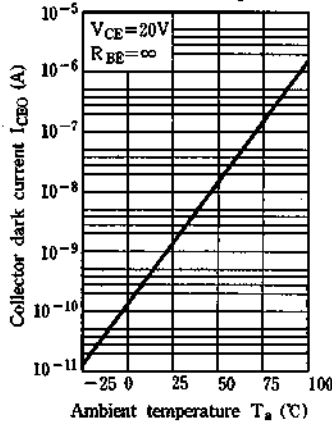

**Fig.10 Collector-base Dark Current vs. Ambient Temperature**

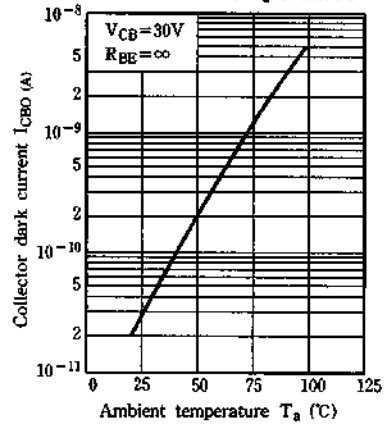

**Fig.11 Response Time vs. Load Resistance**

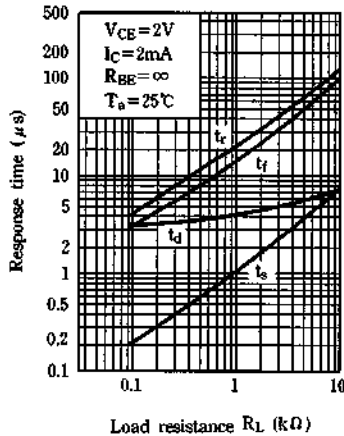

**Fig.12 Frequency Response**

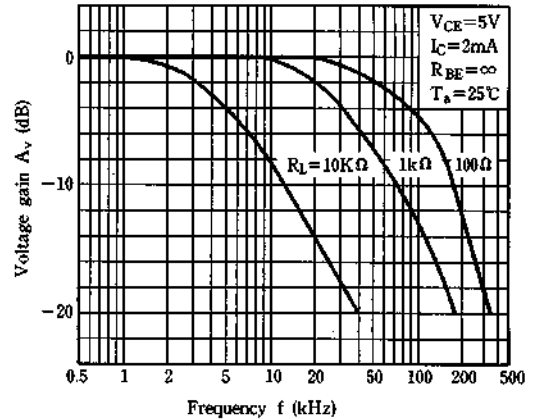

**Test Circuit for Response Time**

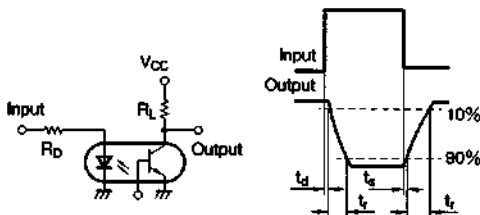

(PC714V has no base terminal.)

**Test Circuit for Frequency Response**

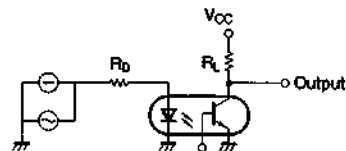

(PC714V has no base terminal.)

● Please refer to the chapter "Precautions for Use". (Page 78 to 93)