



2N3055 MJ2955

COMPLEMENTARY SILICON POWER TRANSISTORS

- STMicroelectronics PREFERRED SALESTYPES
- COMPLEMENTARY NPN-PNP DEVICES

DESCRIPTION

The 2N3055 is a silicon Epitaxial-Base Planar NPN transistor mounted in Jedec TO-3 metal case.

It is intended for power switching circuits, series and shunt regulators, output stages and high fidelity amplifiers.

The complementary PNP type is MJ2955.

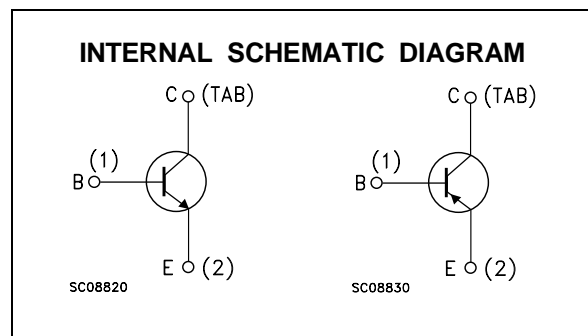
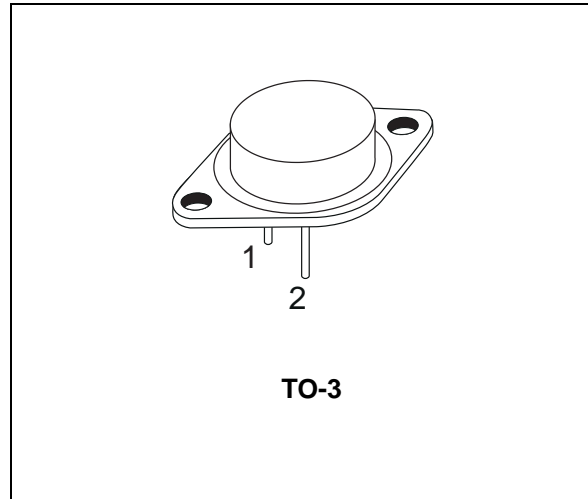

ABSOLUTE MAXIMUM RATINGS

Symbol	Parameter	Value		Unit
		NPN	PNP	
V_{CB0}	Collector-Base Voltage ($I_E = 0$)	100		V
V_{CER}	Collector-Emitter Voltage ($R_{BE} \leq 100\Omega$)	70		V
V_{CEO}	Collector-Emitter Voltage ($I_B = 0$)	60		V
V_{EBO}	Emitter-Base Voltage ($I_C = 0$)	7		V
I_C	Collector Current	15		A
I_B	Base Current	7		A
P_{tot}	Total Dissipation at $T_c \leq 25^\circ\text{C}$	115		W
T_{stg}	Storage Temperature	-65 to 200		$^\circ\text{C}$
T_j	Max. Operating Junction Temperature	200		$^\circ\text{C}$

For PNP types voltage and current values are negative.

2N3055 / MJ2955

THERMAL DATA

R _{thj-case}	Thermal Resistance Junction-case	Max	1.5	°C/W
-----------------------	----------------------------------	-----	-----	------

ELECTRICAL CHARACTERISTICS (T_{case} = 25 °C unless otherwise specified)

Symbol	Parameter	Test Conditions	Min.	Typ.	Max.	Unit
I _{CEX}	Collector Cut-off Current (V _{BE} = -1.5V)	V _{CE} = 100 V V _{CE} = 100 V T _j = 150 °C			1 5	mA mA
I _{CEO}	Collector Cut-off Current (I _B = 0)	V _{CE} = 30 V			0.7	mA
I _{EBO}	Emitter Cut-off Current (I _C = 0)	V _{EB} = 7 V			5	mA
V _{CEO(sus)*}	Collector-Emitter Sustaining Voltage (I _B = 0)	I _C = 200 mA	60			V
V _{CER(sus)*}	Collector-Emitter Sustaining Voltage (R _{BE} = 100 Ω)	I _C = 200 mA	70			V
V _{CE(sat)*}	Collector-Emitter Saturation Voltage	I _C = 4 A I _B = 400 mA I _C = 10 A I _B = 3.3 A			1 3	V V
V _{BE*}	Base-Emitter Voltage	I _C = 4 A V _{CE} = 4 A			1.8	V
h _{FE*}	DC Current Gain	I _C = 4 A V _{CE} = 4 A I _C = 10 A V _{CE} = 4 A	20 5		70	
f _T	Transition frequency	I _C = 0.5 A V _{CE} = 10 V	3			MHz
I _{s/b*}	Second Breakdown Collector Current	V _{CE} = 40 V	2.87			A

TO-3 MECHANICAL DATA

DIM.	mm			inch		
	MIN.	TYP.	MAX.	MIN.	TYP.	MAX.
A	11.00		13.10	0.433		0.516
B	0.97		1.15	0.038		0.045
C	1.50		1.65	0.059		0.065
D	8.32		8.92	0.327		0.351
E	19.00		20.00	0.748		0.787
G	10.70		11.10	0.421		0.437
N	16.50		17.20	0.649		0.677
P	25.00		26.00	0.984		1.023
R	4.00		4.09	0.157		0.161
U	38.50		39.30	1.515		1.547
V	30.00		30.30	1.187		1.193

